

# HEAVY DUTY FLOODED BATTERY

160H52L (12V170Ah)



## CHARACTERISTICS

Item	Specifications	
Nominal Voltage	12V	
Nominal Capacity (20HR)	170Ah	
Reserve Capacity	336min	
Cold Cranking Amps@0°F (-18°C)	940A	
Dimension	Length	521mm (20.5inches)
	Width	261mm (10.3inches)
	Height	240.5mm (9.47inches)
Approx Weight	50.3kg (110.9lbs)	
Terminal	1	
Cell layout	4	
Hold-Down	B0	
Case	Black-PP Material	
Cover	Black-PP Material	
Handle	TS8	

## APPLICATIONS

- Commercial vehicle start
- Engine start

## GENERAL FEATURES

- High capacity and high CCA
- Maintenance-free
- High vibration resistance
- Strong lead-calcium alloy grids for great corrosion resistance
- High strength PP case and cover no need be worried about breakage
- OE quality certification

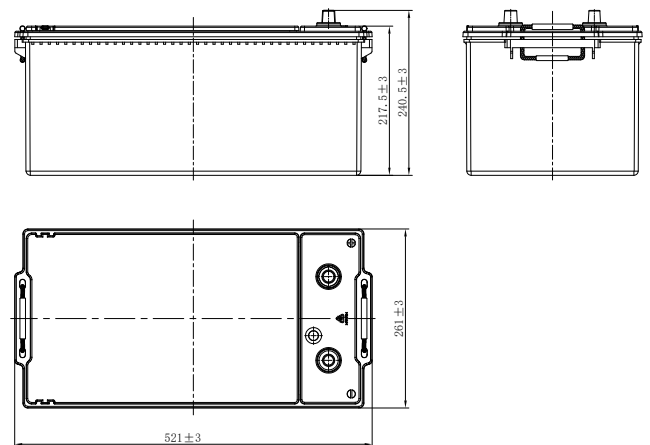
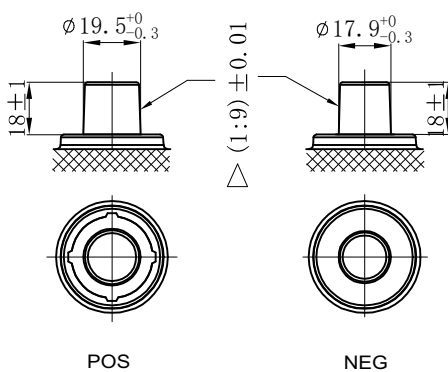

\*Values are subject to variation of +/- 5% in normal manufacturing processes.

Leoch International Technology Ltd.  
[www.leoch.com](http://www.leoch.com)

Leoch Batteries Pte Ltd  
[www.leoch.sg](http://www.leoch.sg)

Leoch Battery Corporation  
[www.leochamericas.com](http://www.leochamericas.com)

Leoch Europe S.A.  
[www.leoch.eu](http://www.leoch.eu)

Data above is recommended and the picture is only for battery effect display, Leoch reserve the final right of explanation.  
 © LEOCH. All rights reserved. Trademarks and logos are the property of LEOCH and its affiliates unless otherwise noted. Subject to revisions without prior notice. E&OE.

Publication No.: LB-160H52L-PD-EN-V1.0-20260608